

# SIGMA

Dual roll toilet tissue dispenser



SIGMA is a dual roll toilet paper dispenser which ensures continuity of paper supply and provides high volume in a compact unit. SIGMA is ideal for low to medium traffic environments and accommodates any toilet roll with a core diameter between 28 and 45mm and with an external diameter up to 140mm.

The unit incorporates intelligent features for service such as a special shield which automatically prevents access to the new toilet roll until the original roll is finished and so reduces paper consumption.

SIGMA also includes a practical inspection window to show when a refill is required and a removable braking system which aids consumable control and minimises waste. The unit is available in Kennedy's full range of attractive finishes for seamless integration with other members of the Kennedy dispenser range.



## Finishes available

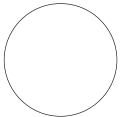

Classic White



Designer Grey

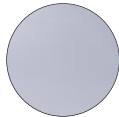

Premium  
Bright Chrome

## Benefits

### Control of Consumables

- > A special shield automatically prevents access to the new roll until the original roll is finished
- > Removable braking system means minimal waste

### Ease of Service

- > Hinged cover for convenience and speed of service
- > Practical inspection window shows when a refill is required

- > One security key for the whole Kennedy range
- > Angled top of dispenser to prevent cigarette burn damage

### End User Satisfaction

- > Hygienic full cover offering tissue protection
- > Serrated paper tear-off from either side of the unit

For more information  
[www.kennedy-hygiene.co.uk](http://www.kennedy-hygiene.co.uk)

# SIGMA

Dual roll toilet tissue dispenser



## Packaging info

	Packed	Qty Per	Weight/Kg	Measurement in cm
SIGMA	Carton	4	3.88	60 x 32 x 21

## Technical drawings

Materials: Constructed mainly from ABS, as well as other engineering thermoplastics. Dispenser can be recycled or disposed of in accordance with local regulations.

Packing: Individual units packed in polythene bags with cardboard dividers in between them.

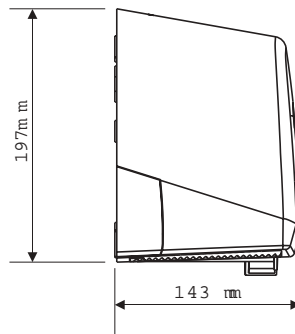
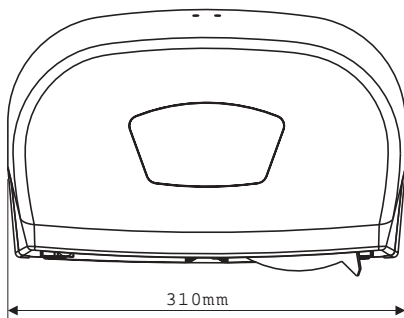

## Consumables

Standard toilet tissue rolls

### Kennedy Hygiene Products Limited

Brookside

Uckfield

East Sussex TN22 1YA

United Kingdom

T +44 (0) 1825 768141

F +44 (0) 1825 768143

E [sales@kennedy-hygiene.com](mailto:sales@kennedy-hygiene.com)

